



# Approaches to Ultra-high Efficiency Solar cells

Christiana Honsberg

Department of Electrical and Computer Engineering  
University of Delaware, Newark, DE

# Photovoltaic Energy Conversion

- Solar cells efficiencies have developed from relatively low values to approaching their efficiency limits.
- Single junction solar cells: ~25% in silicon and GaAs
- Multiple junction tandem: ~37% for three-stack tandem under concentration.
- Corresponds to ~85% of the theoretical limit for single junction solar cells
- Concentrators and tandems have reached ~70% of their material-imposed limits.

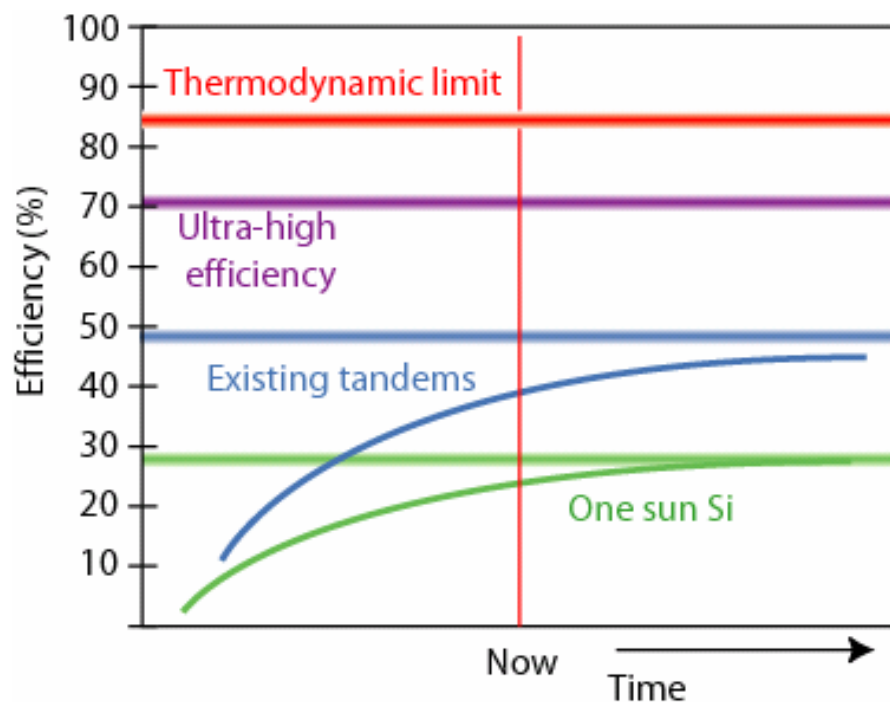

# Solar Cell Efficiencies

- Solar cell losses primarily arise from large range of photon energies in incident spectrum and ability to only utilize energy = band gap.
- Detailed balance calculations quantify these losses, giving single junction efficiency = 30.8% under one sun and 40.8% under max concentration.
- Ultra-high efficiency (sometimes called 3<sup>rd</sup> Generation) approaches are solar cells which can exceed the single-junction efficiency limit.

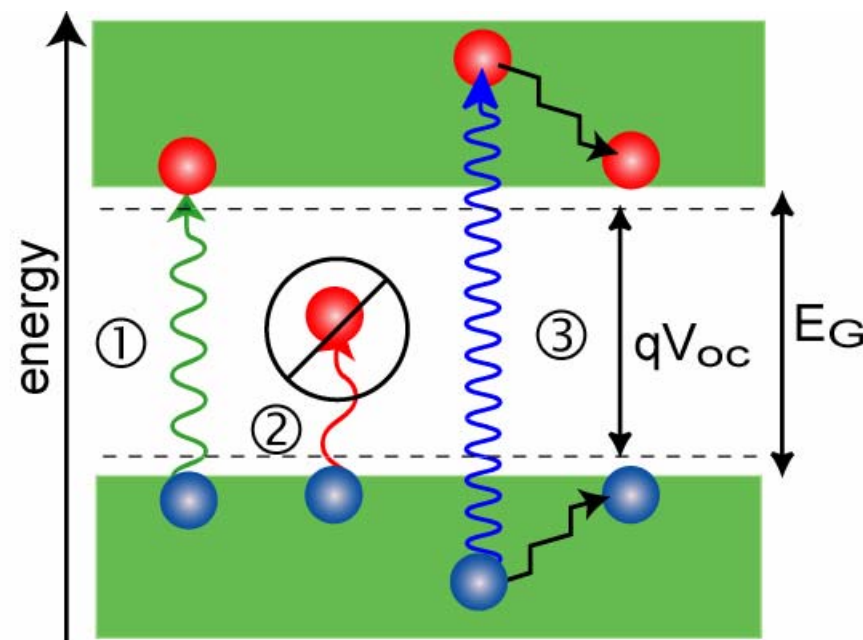
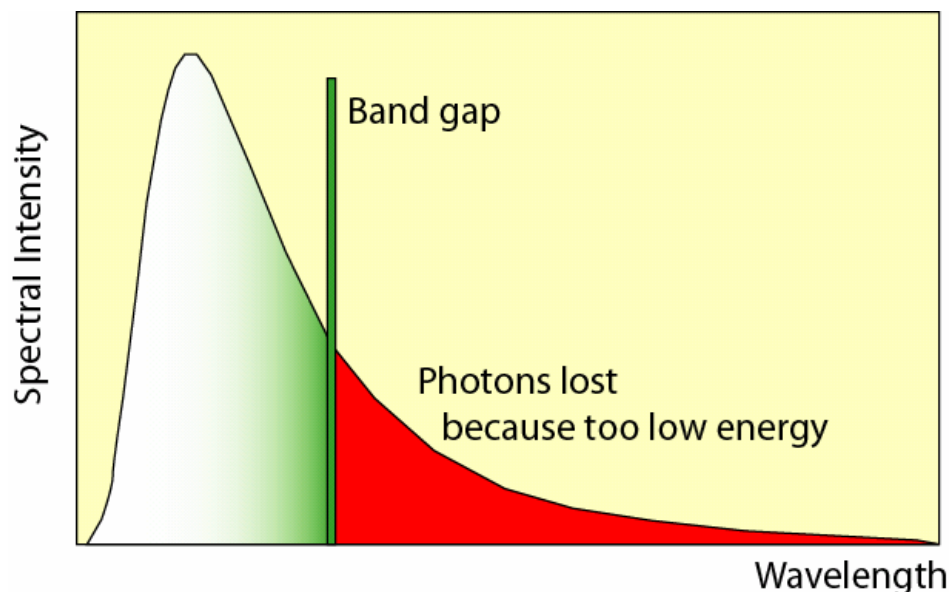



# 1. Multiple Junction Solar Cells

- Multiple junction (tandems) are first class of approaches to exceed single junction efficiency.
- To reach >50% efficiency, need ideal Eg 5-stack tandem or equivalent (assuming can reach ~80% of detailed balance limit).
- Tandem approach limited by existence of materials with suitable band gaps and which can be feasibly incorporated into a solar cell or system.

# junctions in solar cell	1 sun $\eta$	Max con. $\eta$
1 junction	30.8%	40.8%
2 junction	42.9%	55.7%
3 junction	49.3%	63.8%
$\infty$ junction	68.2%	86.8%

**Detailed balance calculations for concentration ratio = 500X**

<i>n</i>	<i>Values of Band Gap (eV)</i>	<i><math>\eta</math> %</i>
4	0.60, 1.11, 1.69, 2.48	62.0
5	0.53, 0.95, 1.40, 1.93, 2.68	65.0
6	0.47, 0.84, 1.24, 1.66, 2.18, 2.93	67.3
7	0.47, 0.82, 1.19, 1.56, 2.0, 2.5, 3.21	68.9
8	0.44, 0.78, 1.09, 1.4, 1.74, 2.14, 2.65, 3.35	70.2



# New approaches to ultra-high efficiency

- Approaches other than tandems determined by examining assumptions in conventional detailed balance and calculating efficiencies by generalized detailed balance.
- Assumptions in conventional detailed balance:
  2. Solar spectrum at a given concentration ratio
  3. One photon = one electron-hole pair
  4. One constant quasi-Fermi level separation
  5. Constant temperature

**Efficiency can be increased to thermodynamic limits by tandems using approaches that circumvent the above assumptions.**

## 2. Multiple Spectrum Solar Cells

- Multiple spectrum devices: take the input solar spectrum, and change it to a new spectrum with the same power density
  - Does not need to be incorporated into solar cell – can use existing solar cells, and add additional optical coatings
  - Approaches for multiple spectrum solar cells.
    - Thermophotonics: Use thermally-excited LED to generate a narrow solar spectrum

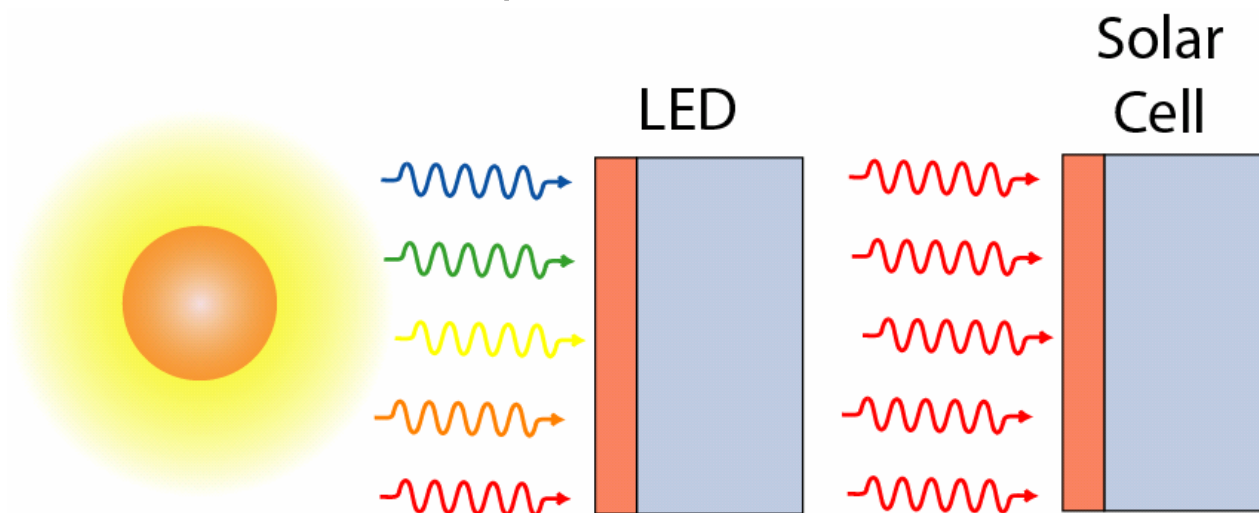

## 2. Multiple Spectrum Solar Cells

- Up/down conversion
  - Involves transformation of narrow regions of solar spectrum to higher or lower energies.
  - Substantial effort in developing efficient down conversion for other applications, eg phosphors.
  - Up/down conversion can be implemented by either material systems or by using approaches such as quantum wells and quantum dots.

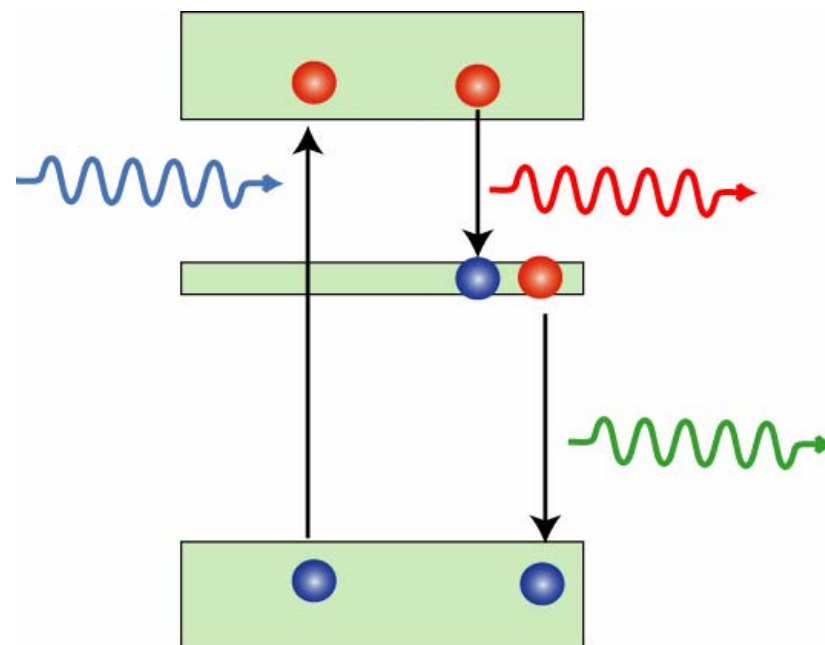



# New approaches to ultra-high efficiency

- Approaches other than tandems determined by examining assumptions in conventional detailed balance and calculating efficiencies by generalized detailed balance.
- Assumptions in conventional detailed balance:
  2. Solar spectrum at a given concentration ratio
  3. **One photon = one electron-hole pair**
  4. One constant quasi-Fermi level separation
  5. Constant temperature

**Efficiency can be increased to thermodynamic limits by tandems using approaches that circumvent the above assumptions.**

### 3. Multiple absorption path (MAP) solar cells

- Change absorption mechanisms such that one photon  $\neq$  one electron-hole pair
- Mechanisms include:
  - Two-photon absorption
  - Impact ionization/Auger generation
- Issues:
  - Effects low in bulk materials
  - Both effects can be made larger in quantum-confined structures
  - Energy threshold for impact ionization affects potential efficiency.
  - For  $E_{th} = 3E_g$  (experimentally demonstrated from nanocrystal quantum dots), detailed balance efficiency = 48%, similar to a two junction tandem.

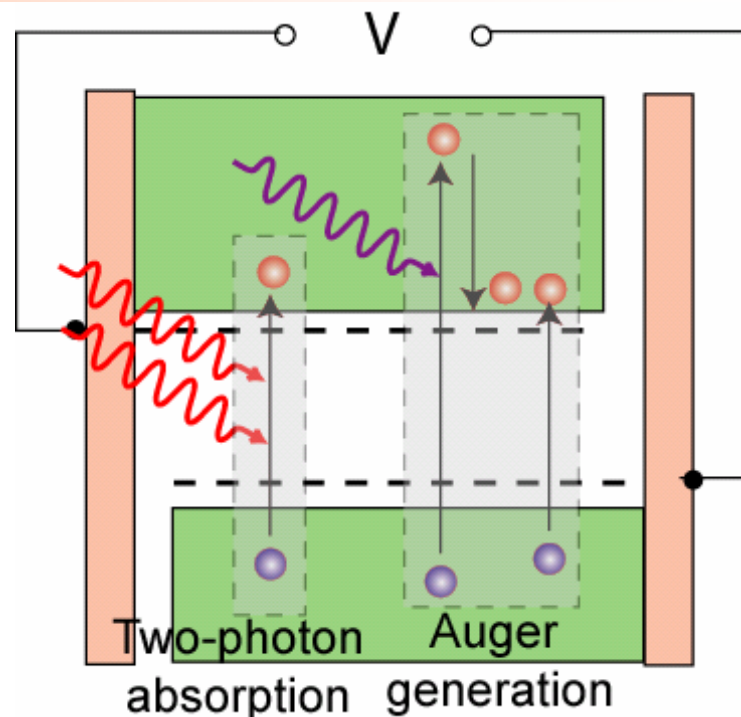



# New approaches to ultra-high efficiency

- Approaches other than tandems determined by examining assumptions in conventional detailed balance and calculating efficiencies by generalized detailed balance.
- Assumptions in conventional detailed balance:
  2. Solar spectrum at a given concentration ratio
  3. One photon = one electron-hole pair
  4. **One constant quasi-Fermi level separation**
  5. Constant temperature

**Efficiency can be increased to thermodynamic limits by tandems using approaches that circumvent the above assumptions.**

# 4. Multiple Energy Level (MEL) Solar Cells

- Introduce more than a single quasi-Fermi level separation by introducing additional energy levels or bands, such that extracted energy of photon  $\neq$  energy of band gap
- Energy levels can be spatially localized (energy levels) or interacting to form mini-bands.

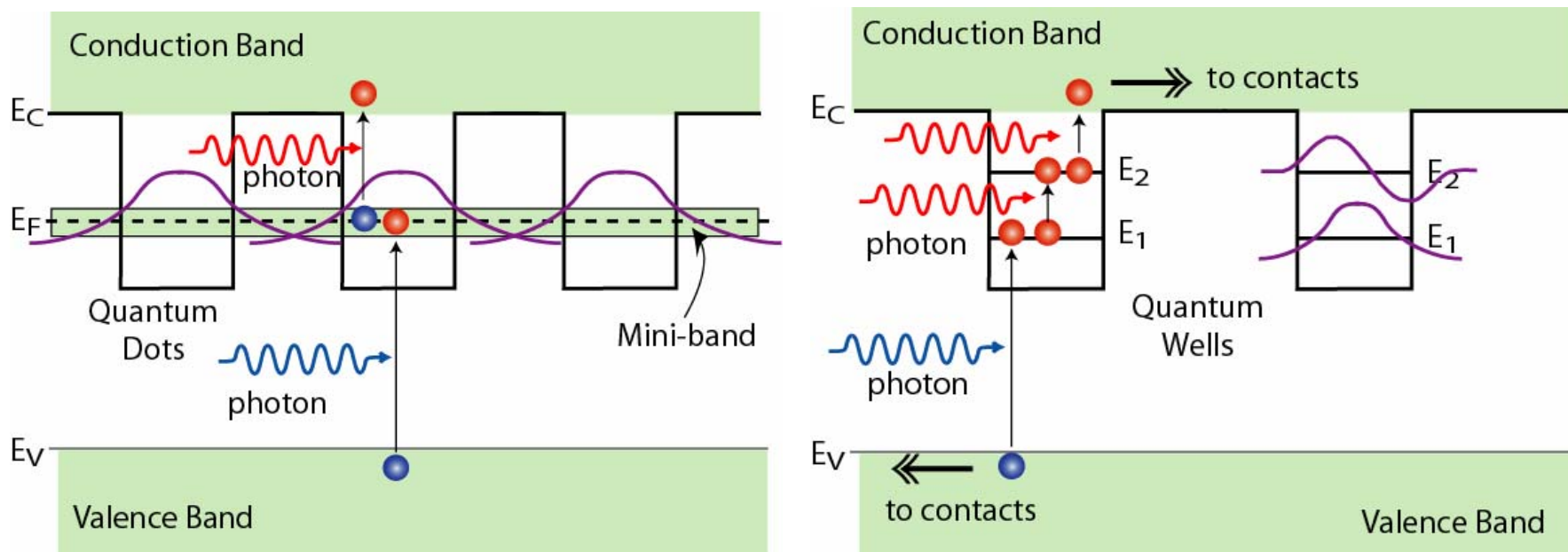

# 4. Multiple Energy Level (MEL) Solar Cells



- Difference between two is transport of carriers.
  - In mini-bands, carriers must not thermalize from one band to another – must use quantum dot approaches.
  - Localized energy levels: transport requires that collection or escape time less than recombination time.

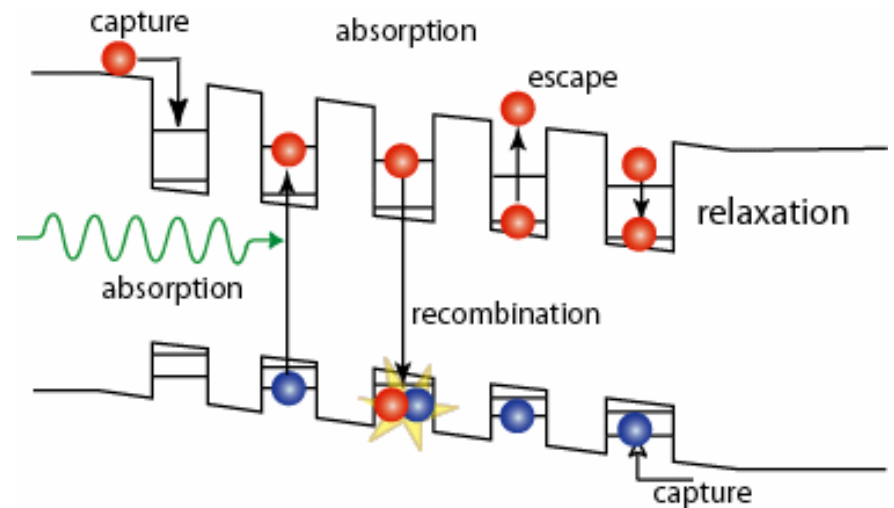
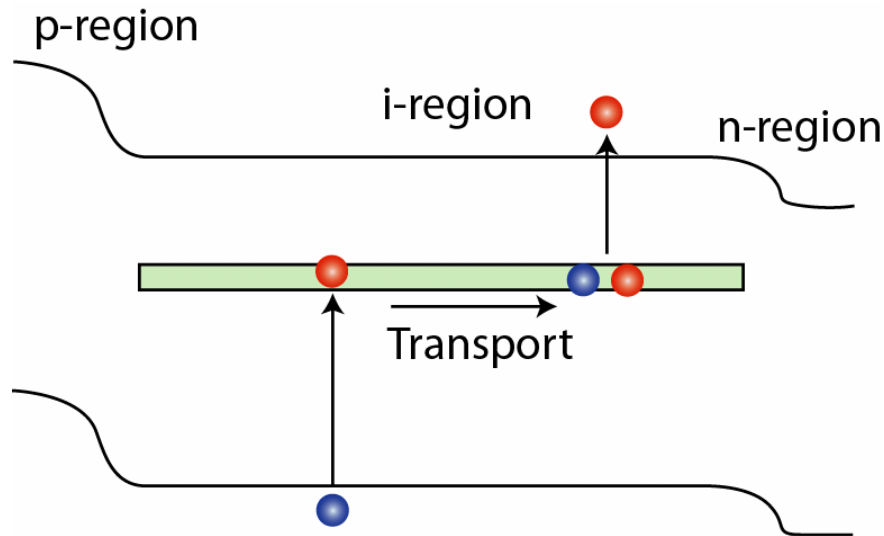



# New approaches to ultra-high efficiency

- Approaches other than tandems determined by examining assumptions in conventional detailed balance and calculating efficiencies by generalized detailed balance.
- Assumptions in conventional detailed balance:
  2. Solar spectrum at a given concentration ratio
  3. One photon = one electron-hole pair
  4. One constant quasi-Fermi level separation
  5. **Constant temperature**

**Efficiency can be increased to thermodynamic limits by tandems using approaches that circumvent the above assumptions.**

# 5. Multiple Temperature Solar Cells

- Multiple temperature solar cells extract energy from temperature differentials in solar cell.
- Possible that temperature differentials are lattice temperature differential, but requires materials with substantially different thermal conductivity than electrical conductivity.
- Easier to maintain a temperature differential in carrier temperature by introducing variations in the band structure.

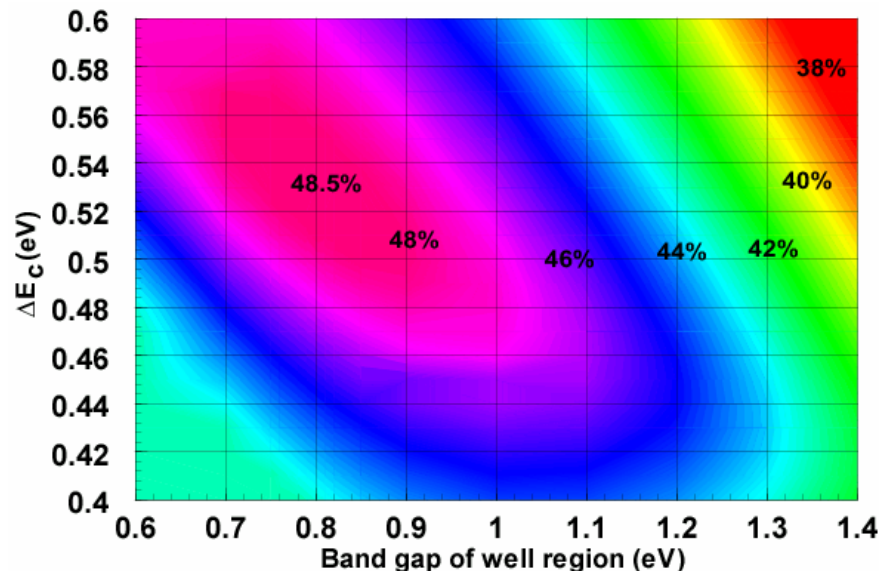
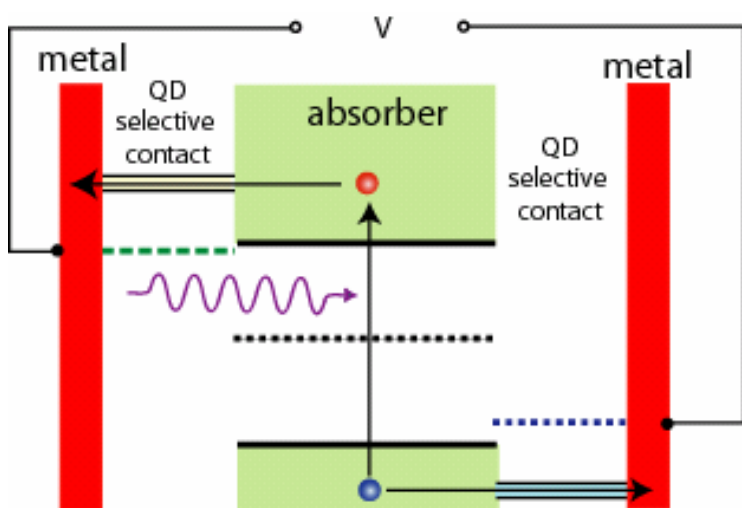



# How to get to > 50%?

- Efficiencies of ultra-high efficiency approaches
  - 1. Tandems: 5-6 junction tandems feasible.
  - 2. Multiple spectrum:
    - Generating narrow spectrum allows high efficiency.
    - Up/down conversion has issues with efficiency, making it suitable for moderate efficiency increase of existing cells.
  - 3. Multiple absorption path:
    - Existing mechanisms can achieve ~ 2 stack tandem assuming it can be transferred to ideal band gaps and other components are completely ideal.
    - Effect demonstrated in potentially low cost approach.



# How to get to > 50%?

- 4. Multiple energy levels:
  - Mini-band approach can theoretically achieve 3-junction tandem efficiency assuming ideal band gaps.
  - Localized approaches can theoretically approach  $\infty$  junction tandem.
- 5. Multiple temperature solar cells:
  - Get equivalent tandem with high number of junctions.
- What structures can be used?
  - Combine new approaches with tandem – get equivalent of ~ 9 junction tandems
  - Localized multiple energy level, multiple temperature



# Physical mechanisms for new approaches

Approach	Match single junction efficiency	Ultra-high efficiency
Multiple Junction	N/A	New materials
Multiple Spectrum	No degradation in solar cell efficiency	Efficient, full spectrum conversion
Multiple Absorption Path	$V_{oc} \approx V_{oc}$ of solar cell without absorption	QE > 1 over substantial range of energy
Multiple Energy Level	No degradation in QE for high $E_g$	Extended QE and multiple quasi-Fermi level
Multiple Temperature	N/A	Demonstration of basic effect

- Several fundamental physical processes to be demonstrated, including improved impact ionization, identification of materials for all approaches, multiple quasi-Fermi levels, new thermal conversion processes.
- Implementation of ultra-high efficiency can be accomplished by:
  - New materials
  - Engineering of band structure using quantum-confinement



# Conclusions

- New approaches to ultra-high efficiency photovoltaics means many more physical mechanisms which can be used for photovoltaic conversion
  - Efficiency of photovoltaics is NOT inherently tied to existence of ideal materials with well specified band gaps.
- Ultra-high efficiency solar cells fall into one of five categories.
- Achieving ultra-high efficiency accomplished by:
  - New materials
  - Development of solar cells with quantum-confinement.
- Substantial fundamental work required to demonstrate basic mechanisms.